

HARRINGTON
HOISTS AND CRANES

KITO



RHN SERIES
ELECTRIC

W I R E R O P E H O I S T S

Working Harder For You

In 1876, Edwin Harrington dramatically improved the self-sustaining hoist by introducing the worm-gear design. Since then, the company he founded has earned a proud reputation for product innovations and consistent quality that our customers count on to meet their diverse requirements.

Over the years we have developed and grown by recognizing the value of our customers and responding to your needs. The daily mission of our organization is to provide you, the customer, with the highest quality in our products, service and support.

In addition to our superior products and expanded facilities, we offer a Sales and Customer Service team that is dedicated to serving you, a well qualified Engineering Department to support your technical needs and a full support staff who all know the importance of working together to provide solutions for your material handling projects.

We are working harder to be the supplier-of-choice for all of your hoist and crane applications.

Table of Contents

RHN Series Electric Wire Rope Hoists	
Features and Benefits	4
RHN Series Electric Wire Rope Hoists Deck/Base Mounted Hoists	
Standard Specifications and Dimensions	6
RHN Series Electric Wire Rope Hoists Ultra-Low Headroom Trolley Hoists	
Standard Specifications and Dimensions	10
Ultra-Low Headroom Trolley Hoist – Headroom	14
Ultra-Low Headroom Trolley – Motor Dimensions	14
Options and Technical Data	
Deck/Base Mounted Attachment Points – Dimensions	15
Bottom Hook – Dimensions	17
Reaction Forces at Rated Load	18
Trolley Wheel Dimensions	20
Variable Frequency Drive (VFD)	21
Duty Classifications	21
Lifting Motor Ratings	21
Compliance	22
Product Code	22
Complete Product Offering	23

RHN Series Electric Wire Rope Hoists

Easy Maintenance Control Panel

IP55 protection with modern controls. Components mounted on DIN rail. Equipped with main line contactor.

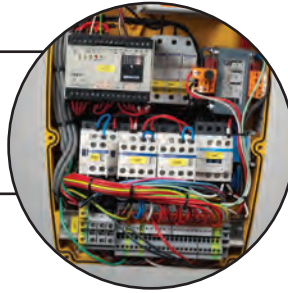

Adjustable Geared Limit Switch

Operation of switch set for upper and lower block position and emergency limit.

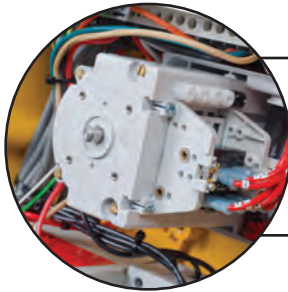

Motor Management

Equipped with overload cut-off and count hour meter.

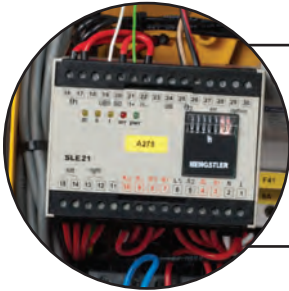

Helical Gearing

Provides maintenance free, smooth and quiet operation.

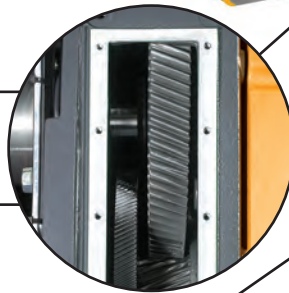

Heavy Duty Cylindrical Motor

Fan cooled (TEFC) with class F insulation and a ribbed frame for maximum cooling and durability. High protection class IP55 and positive temperature control (PTC) thermal sensors.

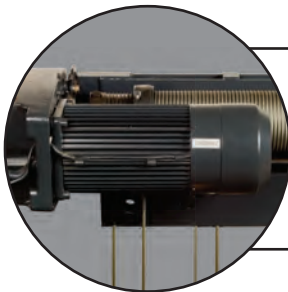

Heavy Duty Electromagnetic Brake

Totally enclosed and fan cooled to ensure long life. Easy to inspect. 1 million cycles.

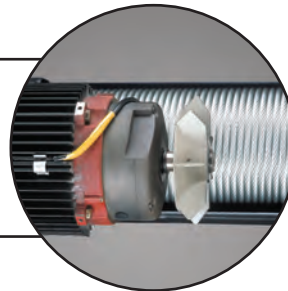

Load Limiter

Reduces the potential for making hazardous, over-capacity lifts. Overloading the hoist electrically activates the load limiter sensor, making hoist lifting inoperable.



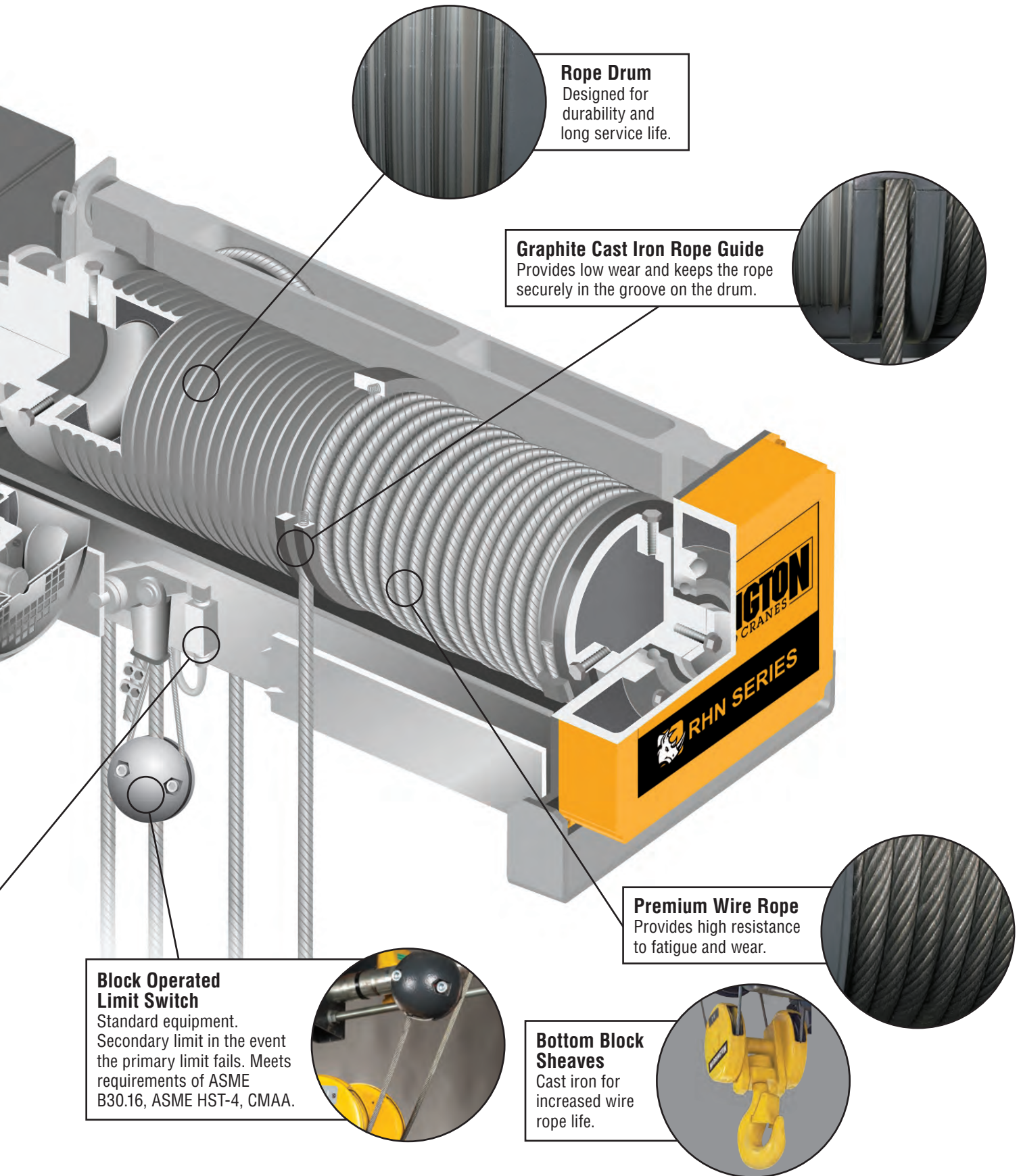

Rope Drum
Designed for durability and long service life.

Graphite Cast Iron Rope Guide
Provides low wear and keeps the rope securely in the groove on the drum.

Premium Wire Rope
Provides high resistance to fatigue and wear.

Bottom Block Sheaves
Cast iron for increased wire rope life.

Block Operated Limit Switch
Standard equipment. Secondary limit in the event the primary limit fails. Meets requirements of ASME B30.16, ASME HST-4, CMAA.

RHN Series Electric Wire Rope Deck/Base Mounted Hoists

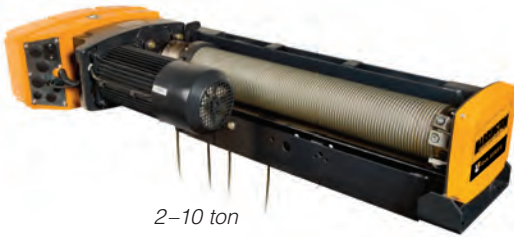

2-10 ton

Harrington's high performance RHN Series Deck / Base Mounted electric wire rope hoists feature a compact, modular design that is perfect for stationary applications or combined with a double girder trolley for double girder crane systems. The basic design is ideal for hoist retro-fits on existing crane applications.

Features and Benefits

Premium Wire Rope

Provides high resistance to fatigue and wear.

Graphite Cast Iron Rope Guide

Provides low wear and keeps the rope securely in the groove on the drum.

Load Limiter

Reduces the potential for making hazardous, over-capacity lifts. Overloading the hoist electrically activates the load limiter sensor, making hoist lifting inoperable.

Helical Gearing

Provides maintenance free, smooth & quiet operation.

Easy Maintenance Control Panel

IP55 protection with modern controls. Components mounted on DIN rail. Equipped with main line contactor.

Heavy Duty Electromagnetic Brake

Totally enclosed and fan cooled to ensure long life. Easy to inspect. 1 million cycles.

Heavy Duty Cylindrical Motor

Fan cooled (TEFC) with class F insulation and a ribbed frame for maximum cooling and durability. High protection class IP55 and positive temperature control (PTC) thermal sensors.

Bottom Block Sheaves

Cast iron for increased wire rope life.

Rope Drum

Designed for durability and long service life.

Adjustable Geared Limit Switch

Operation of switch set for upper and lower block position and emergency limit.

Motor Management

Equipped with overload cut-off and count hour meter.

Block Operated Limit Switch

Standard equipment. Secondary limit in the event the primary limit fails. Meets requirements of ASME B30.16, ASME HST-4, CMAA.

Standard Hoist Specifications

Capacity Range

2 – 20 ton

Standard Voltage

208 / 230 / 460 / 575-3-60

RHN models are not reconnectable

Control Voltage

110V

Duty Cycle

30 / 10 min

Classification

ASME H4

ISO M5 or M4

FEM 2M or 1Am

Conformance

ASME B30.16

CMAA

UL508A

CSA C22.2 NO.14

Ratings

Hoist – IP55

Standard Lift

20' or 33'

Reeving

4/1 (four-part single reeved)

Operating Conditions

Recommended for -4° to +104° F and humidity of 85% or less.

Adjustable Geared Limit Switch

Upper and lower standard

Mounting

Deck / Base mount

Consult Customer Service for Suspended Mount applications

Pendant & Pendant Cord

Optional

Power Supply Cord

Optional

Variable Frequency Drive (VFD)

Consult Customer Service

HARRINGTON RHN SERIES ELECTRIC WIRE ROPE HOISTS



Zentrtec
Material Handling

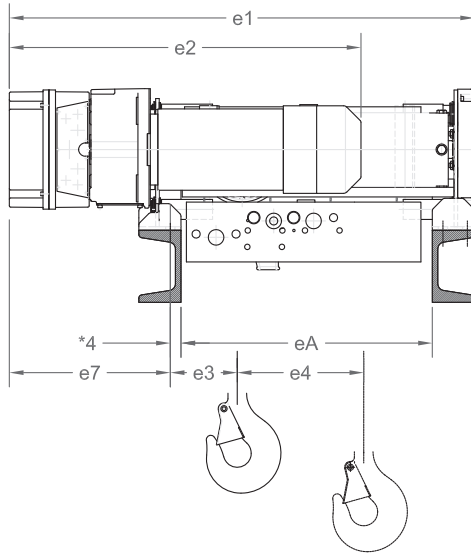

2-10 ton

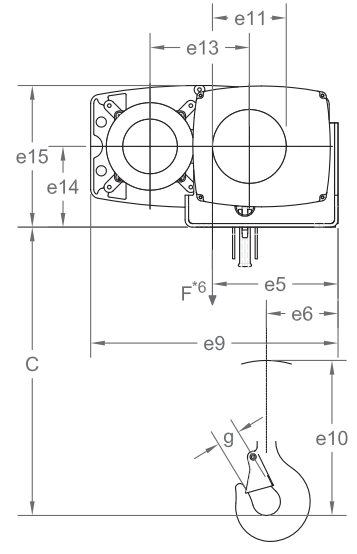

2-10 ton

DECK/BASE MOUNTED HOISTS—SPECIFICATIONS

Capacity (t)	Product Code	Lift (ft)	Dual Lifting Speed (ft/min)	Reeving (parts/reeving)	Rope (mm)	Dual Speed Lifting Motor 3 Phase 60Hz				Net Weight (lbs)
						Output (Hp)	Rated Current (amps)			
							@208/230V	@460V	@575V	
2	RHN02D-20A-20D-①	20	20/3.5	4/1	7	5.8/0.9	17.4/8.4	8.3/4.0	6.6/3.2	353
	RHN02D-33A-20D-①	33								375
3	RHN03D-20A-20D-①	20	20/3.5	4/1	7	5.8/0.9	17.4/8.4	8.3/4.0	6.6/3.2	353
	RHN03D-33A-20D-①	33								375
5	RHN05D-20B-20D-①	20	20/3.5	4/1	9	7.2/1.2	21.7/11.3	10.0/5.4	8.3/4.3	452
	RHN05D-33B-20D-①	33								485
7 1/2	RHN08D-20C-20D-①	20	20/3.5	4/1	12.5	14.8/2.1	41.8/20.9	20.0/10.0	16.0/8.0	1025
	RHN08D-33C-20D-①	33								1102
10	RHN10D-20C-20D-①	20	20/3.5	4/1	12.5	14.8/2.1	41.8/20.9	20.0/10.0	16.0/8.0	1025
	RHN10D-33C-20D-①	33								1102

① 1 = 208V - 3ph - 60Hz
 2 = 230V - 3ph - 60Hz
 4 = 460V - 3ph - 60Hz
 5 = 575V - 3ph - 60Hz

Consult Customer Service for Suspended Mount applications.

RHN Series Electric Wire Rope Deck/Base Mounted Hoists

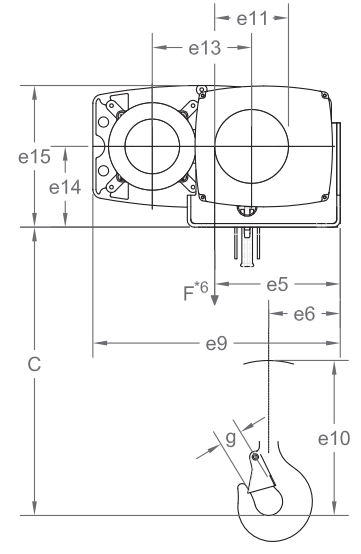
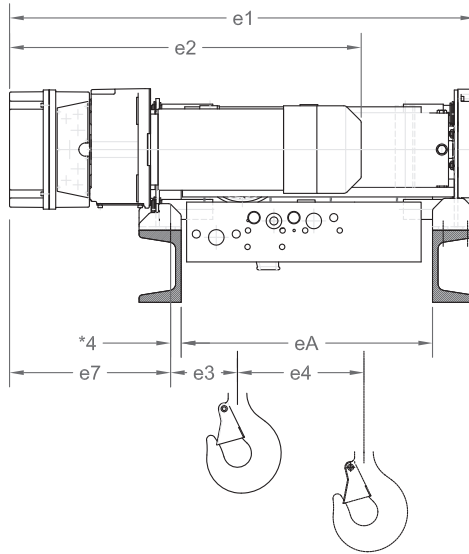
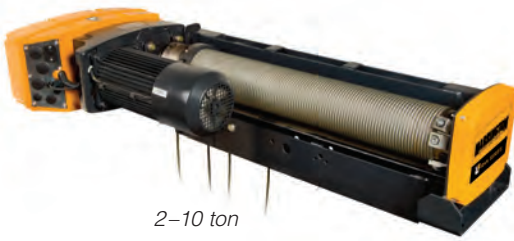

DECK/BASE MOUNTED HOISTS—DIMENSIONS

Capacity (t)	Product Code	Headroom C (in)	e1 (in)	e2 (in)	e3 (in)	e4 (in)	e5 (in)	e6 (in)	e7 (in)	e9 (in)	e10 (in)	e11 (in)	e13 (in)	e14 (in)	e15 (in)	eA (in)
2	RHN02D-20A-20D-①	16.7	40.9	28.5	6.3	4.6	9.0	4.8	13.9	21.3	11.5	5.0	7.2	6.3	11.0	22.2
	RHN02D-33A-20D-①		52.5		6.2	7.6										33.8
3	RHN03D-20A-20D-①	16.7	40.9	28.5	6.3	4.6	9.0	4.8	13.9	21.3	11.5	5.0	7.2	6.3	11.0	22.2
	RHN03D-33A-20D-①		52.5		6.2	7.6										33.8
5	RHN05D-20B-20D-①	18.9	41.3	31.2	6.4	4.3	11.2	5.9	14.3	22.0	13.8	6.6	8.8	7.2	12.9	22.2
	RHN05D-33B-20D-①		52.9			7.2										33.8
7 1/2	RHN08D-20C-20D-①	24.6	48.0	39.3	9.5	4.6	14.1	7.5	17.2	28.6	18.2	8.6	11.7	9.4	16.9	24.6
	RHN08D-33C-20D-①		60.4			7.8										37.0
10	RHN10D-20C-20D-①	24.6	48.0	39.3	9.5	4.6	14.1	7.5	17.2	28.6	18.2	8.6	11.7	9.4	16.9	24.6
	RHN10D-33C-20D-①		60.4			7.8										37.0

- ① 1 = 208V - 3ph - 60Hz
- 2 = 230V - 3ph - 60Hz
- 4 = 460V - 3ph - 60Hz
- 5 = 575V - 3ph - 60Hz

Consult Customer Service for Suspended Mount applications.
See page 15 for dimensions of Deck/Base Mounted attachment points.
*4 - Keep this dimension as small as possible.
*6 - Traction on drum.

HARRINGTON RHN SERIES ELECTRIC WIRE ROPE HOISTS

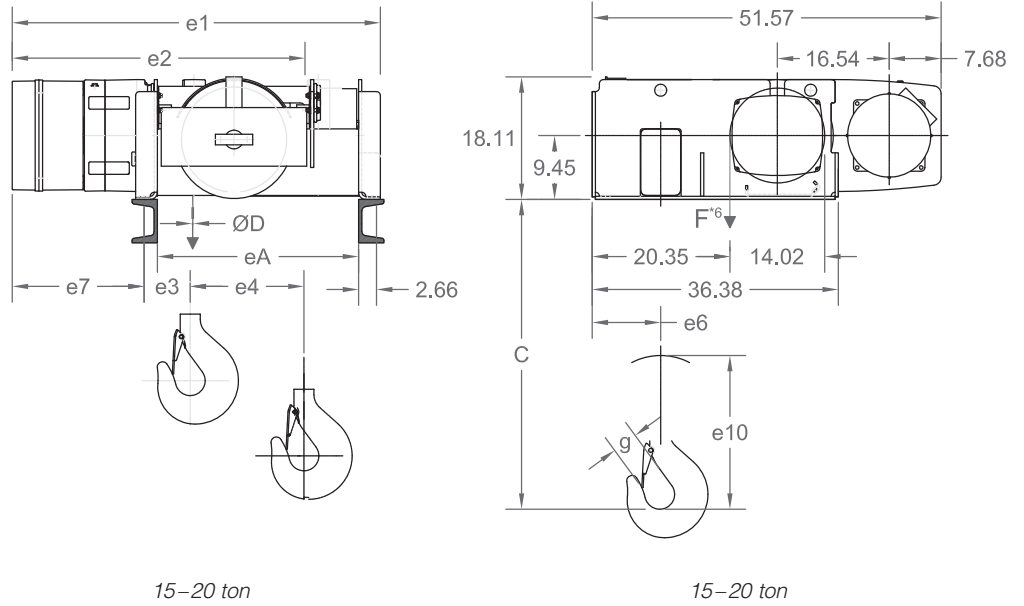

DECK/BASE MOUNTED HOISTS—LARGE CAPACITY SPECIFICATIONS

Capacity (t)	Product Code	Lift (ft)	Dual Lifting Speed (ft/min)	Reeving (parts/reeving)	Rope (mm)	Dual Speed Lifting Motor 3 Phase 60Hz				Net Weight (lbs)
						Output (Hp)	Rated Current (amps)			
							@208/230V	@460V	@575V	
15	RHN15D-20D-16D-①	20	16/2.5	4/1	20	24.1/4.0	66.9/27.2	32.0/13.0	25.6/10.4	2271
	RHN15D-33D-16D-①	33								2436
20	RHN20D-20D-16D-①	20	16/2.5	4/1	20	24.1/4.0	66.9/27.2	32.0/13.0	25.6/10.4	2271
	RHN20D-33D-16D-①	33								2436

①
 1 = 208V - 3ph - 60Hz
 2 = 230V - 3ph - 60Hz
 4 = 460V - 3ph - 60Hz
 5 = 575V - 3ph - 60Hz

DECK/BASE MOUNTED HOISTS—LARGE CAPACITY DIMENSIONS

Capacity (t)	Product Code	Headroom C (in)	e1 (in)	e2 (in)	e3 (in)	e4 (in)	e6 (in)	e7 (in)	e10 (in)	eA (in)
15	RHN15D-20D-16D-①	31.1	54.4	43.5	13.4	4.6	10.9	19.5	29.8	28.3
	RHN15D-33D-16D-①		66.7			7.6				40.6
20	RHN20D-20D-16D-①	31.1	54.4	43.5	13.4	4.6	10.9	19.5	29.8	28.3
	RHN20D-33D-16D-①		66.7			7.6				40.6

①
 1 = 208V - 3ph - 60Hz
 2 = 230V - 3ph - 60Hz
 4 = 460V - 3ph - 60Hz
 5 = 575V - 3ph - 60Hz

Consult Customer Service for Suspended Mount applications.
 See page 16 for dimensions of Deck/Base Mounted attachment points.
 *6 - Traction on drum.

RHN Series Electric Wire Rope Ultra-Low Headroom Trolley Hoists



2–15 ton

Harrington's RHN Series Ultra-Low Headroom trolley hoists combine our superior RHN hoist with an ultra-low headroom trolley and is the ideal solution for top running and underhung overhead bridge cranes. The compact body and short end approach result in the longest hook travel possible in facilities with limited usable space.

Features and Benefits

Rubber Trolley Bumpers

Standard feature on all trolleys. Provides protection from collisions. Complies with ASME standards.

Trolley Motor and Brake

Cylindrical motor with standard brake provides smooth, low-vibration acceleration and braking.

Built-In Drop Stops

Important feature provides additional security for the operator and the equipment.

Trolley Wheels

2 and 3 ton are operational on 3 1/4" patented track.

Premium Wire Rope

Provides high resistance to fatigue and wear.

Graphite Cast Iron Rope Guide

Provides low wear and keeps the rope securely in the groove on the drum.

Load Limiter

Reduces the potential for making hazardous, over-capacity lifts. Overloading the hoist electrically activates the load limiter sensor, making hoist lifting inoperable.

Helical Gearing

Provides maintenance free, smooth & quiet operation.

Easy Maintenance Control Panel

IP55 protection with modern controls. Components mounted on DIN rail. Equipped with main line contactor.

Heavy Duty Cylindrical Motor

Fan cooled (TEFC) with class F insulation and a ribbed frame for maximum cooling and durability. High protection class IP55 and positive temperature control (PTC) thermal sensors.

Heavy Duty Electromagnetic Brake

Totally enclosed and fan cooled to ensure long life. Easy to inspect. 1 million cycles.

Bottom Block Sheaves

Cast iron for increased wire rope life.

Rope Drum

Designed for durability and long service life.

Adjustable Geared Limit Switch

Operation of switch set for upper and lower block position and emergency limit.

Motor Management

Equipped with overload cut-off and count hour meter.

Block Operated Limit Switch

Standard equipment. Secondary limit in the event the primary limit fails. Meets requirements of ASME B30.16, ASME HST-4, CMAA.

Standard Hoist/Trolley Specifications

Capacity Range

2 – 15 ton

Standard Voltage

208 / 230 / 460 / 575-3-60

RHN models are not reconnectable.

Control Voltage

110V

Duty Cycle

30 / 10 min

Ratings

Hoist / Trolley – IP55

Classification

ASME H4
ISO M5 or M4
FEM 2M or 1Am

Conformance

ASME B30.16
CMAA
UL508A
CSA 22.2 NO.14

Operating Conditions

Recommended for -4° to +104° F and humidity of 85% or less.

Mounting

Ultra-Low Headroom

Pendant & Pendant Cord

Optional

Power Supply Cord

Optional

Wheels

Will operate on a tapered or flat flanged beam flange.

Variable Frequency Drive (VFD)

Hoist - Consult Customer Service
Trolley - Consult Customer Service

HARRINGTON RHN SERIES ELECTRIC WIRE ROPE HOISTS



2-15 ton

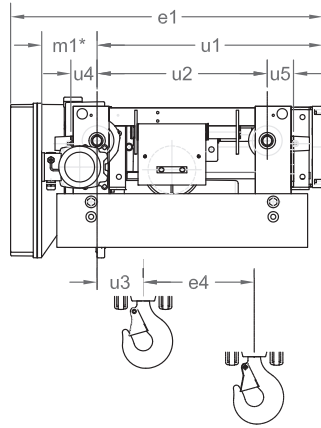

2-15 ton

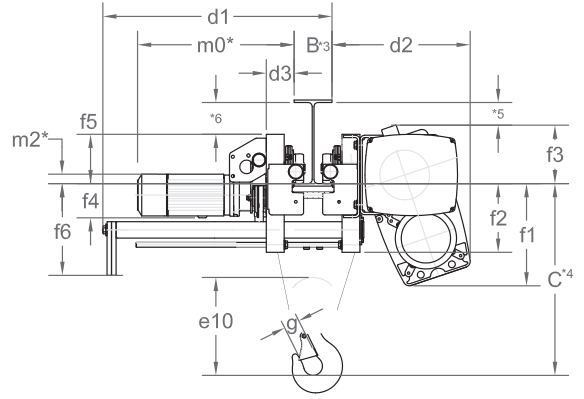

2-15 ton

ULTRA-LOW HEADROOM TROLLEY HOISTS—HOIST SPECIFICATIONS

Capacity (t)	Product Code	Lift (ft)	Dual Lifting Speed (ft/min)	Reeving (parts/reeving)	Rope (mm)	Dual Speed Lifting Motor 3 Phase 60Hz				Net Weight (lbs)
						Output (Hp)	Rated Current (amps)			
							@208/230V	@460V	@575V	
2	RHN02U-20A-20DD-①	20	20/3.5	4/1	7	5.8/0.9	17.4/8.4	8.3/4.0	6.6/3.2	617
	RHN02U-33A-20DD-①	33								650
3	RHN03U-20A-20DD-①	20	20/3.5	4/1	7	5.8/0.9	17.4/8.4	8.3/4.0	6.6/3.2	617
	RHN03U-33A-20DD-①	33								650
5	RHN05U-20B-20DD-①	20	20/3.5	4/1	9	7.2/1.2	21.7/11.3	10.0/5.4	8.3/4.3	728
	RHN05U-33B-20DD-①	33								787
7 1/2	RHN08U-20C-20DD-①	20	20/3.5	4/1	12.5	14.8/2.1	41.8/20.9	20.0/10.0	16.0/8.0	1664
	RHN08U-33C-20DD-①	33								1753
10	RHN10U-20C-20DD-①	20	20/3.5	4/1	12.5	14.8/2.1	41.8/20.9	20.0/10.0	16.0/8.0	1664
	RHN10U-33C-20DD-①	33								1753
15	RHN15U-28D-12DD-①	28	12/2.0	4/1	14	14.8/2.1	41.8/20.9	20.0/10.0	16.0/8.0	3086
	RHN15U-46D-12DD-①	46								3439

① 1 = 208V - 3ph - 60Hz
 2 = 230V - 3ph - 60Hz
 4 = 460V - 3ph - 60Hz
 5 = 575V - 3ph - 60Hz

RHN Series Electric Wire Rope Ultra-Low Headroom Trolley Hoists



2–15 ton

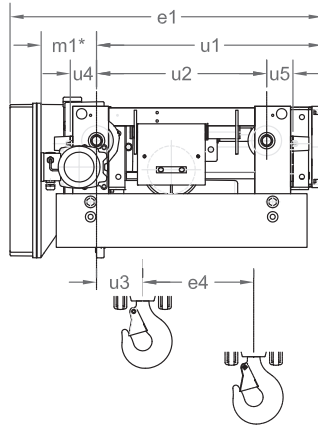

2–15 ton

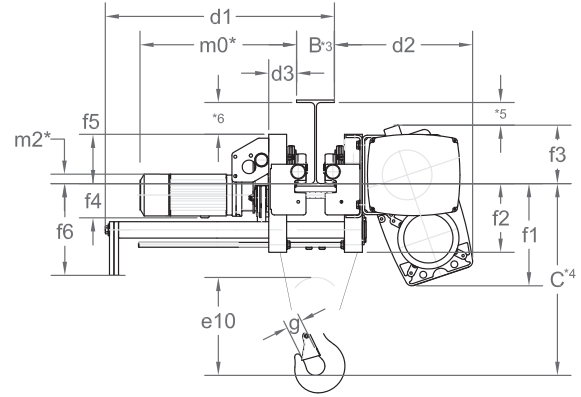

2–15 ton

ULTRA-LOW HEADROOM TROLLEY HOISTS—TROLLEY SPECIFICATIONS

Capacity (t)	Product Code	Standard Flange Range B* (in)	Dual Speed Traversing Motor 80 and 20 ft/min				
			Output (Hp)	Rated Current (amps)			
				@208V	@230V	@460V	@575V
2	RHN02U-20A-20DD-①	3.25-12	0.15/0.59	2.3/3.0	2.0/2.6	1.0/1.3	0.8/1.0
	RHN02U-33A-20DD-①						
3	RHN03U-20A-20DD-①	3.25-12	0.15/0.59	2.3/3.0	2.0/2.6	1.0/1.3	0.8/1.0
	RHN03U-33A-20DD-①						
5	RHN05U-20B-20DD-①	3.63-12	0.15/0.59	2.3/3.0	2.0/2.6	1.0/1.3	0.8/1.0
	RHN05U-33B-20DD-①						
7 1/2	RHN08U-20C-20DD-①	4.63-12	0.21/0.89	2.8/3.7	2.4/3.2	1.2/1.6	1.0/1.3
	RHN08U-33C-20DD-①						
10	RHN10U-20C-20DD-①	4.63-12	0.21/0.89	2.8/3.7	2.4/3.2	1.2/1.6	1.0/1.3
	RHN10U-33C-20DD-①						
15	RHN15U-28D-12DD-①	8.75-12	0.48/2.01	3.2/6.9	2.8/6.0	1.4/3.0	1.1/2.4
	RHN15U-46D-12DD-①						

① 1 = 208V – 3ph – 60Hz
 2 = 230V – 3ph – 60Hz
 4 = 460V – 3ph – 60Hz
 5 = 575V – 3ph – 60Hz

*Optional wider flange ranges available up to 19.7 inches. Consult Customer Service.

HARRINGTON RHN SERIES ELECTRIC WIRE ROPE HOISTS



2–15 ton

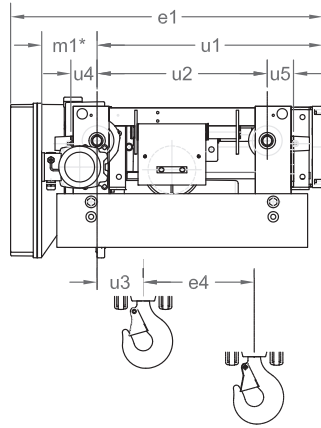

2–15 ton

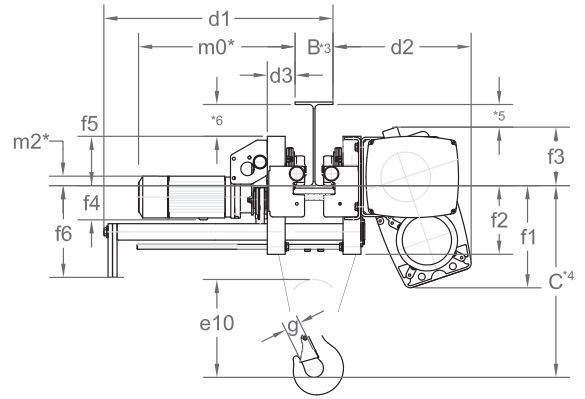

2–15 ton

ULTRA-LOW HEADROOM TROLLEY HOISTS—DIMENSIONS

Capacity (t)	Product Code	e1 (in)	e4 (in)	e10 (in)	d1 (in)	d2 (in)	d3 (in)	f1 (in)	f2 (in)	f3 (in)	f4 (in)	f5 (in)	f6 (in)	u1 (in)	u2 (in)	u3 (in)	u4 (in)	u5 (in)
2	RHN02U-20A-20DD-①	44.3	4.6	11.5	28.7	17.5	3.7	13.9	8.9	6.5	4.8	6.1	11.9	30.0	22.4	9.1	3.0	3.8
	RHN02U-33A-20DD-①	59.8	7.6										10.7	41.6	34.1	9.0		
3	RHN03U-20A-20DD-①	44.3	4.6	11.5	28.7	17.5	3.7	13.9	8.9	6.5	4.8	6.1	11.9	30.0	22.4	9.1	3.0	3.8
	RHN03U-33A-20DD-①	59.8	7.6										10.7	41.6	34.1	9.0		
5	RHN05U-20B-20DD-①	49.1	4.3	13.8	31.4	18.2	3.7	13.5	9.1	7.7	4.8	6.5	12.1	29.8	22.4	9.9	3.5	3.5
	RHN05U-33B-20DD-①	60.9	7.2							8.1		8.1	10.9	47.3	40.0	15.8		
7 1/2	RHN08U-20C-20DD-①	47.2	4.6	18.2	37.0	22.9	4.5	16.1	11.4	10.7	5.9	9.8	15.7	33.7	24.6	12.6	4.6	4.6
	RHN08U-33C-20DD-①	59.6	7.8										15.0	46.1	37.0	12.6		
10	RHN10U-20C-20DD-①	47.2	4.6	18.2	37.0	22.9	4.5	16.1	11.4	10.7	5.9	9.8	15.7	33.7	24.6	12.6	4.6	4.6
	RHN10U-33C-20DD-①	59.6	7.8										15.0	46.1	37.0	12.6		
15*	RHN15U-28D-12DD-①	53.9	4.6	23.0	44.4	25.1	6.6	24.5	11.8	10.0	6.6	10.0	16.7	38.0	40.7	15.9	6.6	6.6
	RHN15U-46D-12DD-①	66.1	7.7										15.2	58.1	60.8	23.7		

- ① 1 = 208V – 3ph – 60Hz
- 2 = 230V – 3ph – 60Hz
- 4 = 460V – 3ph – 60Hz
- 5 = 575V – 3ph – 60Hz

*Refer to page 14 for motor dimensions m0, m1, and m2.

*3 – Refer to page 14 for flange range dimension B (Standard Ultra-Low Headroom trolleys are suitable for use on S or W shaped beams).

*4 – Refer to page 14 for headroom dimension C.

*5/*6 – Observe clearance dimensions.

RHN Series Electric Wire Rope Ultra-Low Headroom Trolley Hoists

ULTRA-LOW HEADROOM TROLLEY HOIST—HEADROOM

Capacity (t)	Flange Range B (in)	Headroom C* (in)	Headroom C for 6 inch Flange (in)
2 3	3.25-4.69	16.54	16.2
	4.69-6.69	17.9+(-0.29*T)	
	6.69-12	12.1+(0.58*T)	
5	3.625-4.69	20.67	20.5
	4.69-6.69	21.1+(-0.10*T)	
	6.69-12	22.0+(-0.23*T)	
7.5 10	4.625-6.69	25.6+(-0.29*T)	23.9
	6.69-12	25.9+(-0.35*T)	
15	8.75-12	31.4+(-0.31*T)	28.6**

*T in formulas is the exact beam flange width in inches.
**Headroom value for 9 inch flange.

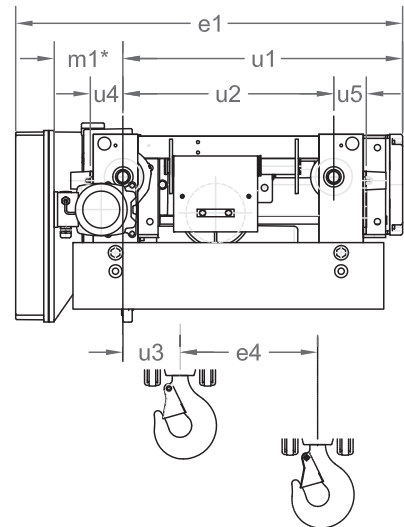

ULTRA-LOW HEADROOM TROLLEY—MOTOR DIMENSIONS*

Capacity (t)	Product Code	m0 (in)	m1 (in)	m2 (in)
2	RHN02U-20A-20DD-①	20.6	7.4	1.3
	RHN02U-33A-20DD-①			
3	RHN03U-20A-20DD-①	20.6	7.4	1.3
	RHN03U-33A-20DD-①			
5	RHN05U-20B-20DD-①	20.6	7.4	1.3
	RHN05U-33B-20DD-①			
7 1/2	RHN08U-20C-20DD-①	22.3	9.5	0.8
	RHN08U-33C-20DD-①			
10	RHN10U-20C-20DD-①	22.3	9.5	0.8
	RHN10U-33C-20DD-①			
15	RHN15U-28D-12DD-①	26.5	10.1	1.3
	RHN15U-46D-12DD-①			

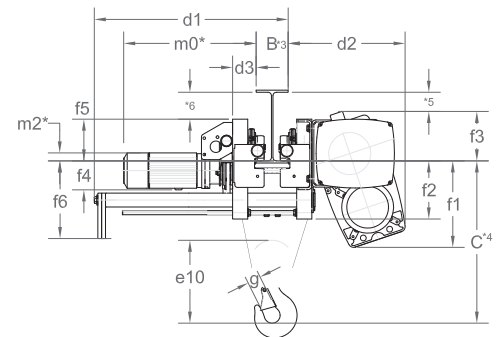

①
1 = 208V - 3ph - 60Hz
2 = 230V - 3ph - 60Hz
4 = 460V - 3ph - 60Hz
5 = 575V - 3ph - 60Hz

*Refer to page 12 for trolley motor specifications.

Options and Technical Data

DECK/BASE MOUNTED ATTACHMENT POINTS—DIMENSIONS

Capacity (t)	Product Code	e1 (in)	e12 (in)	Deck/Base Mounted
2	RHN02D-20A-20D-①	40.9	24.2	
	RHN02D-33A-20D-①	52.5	35.8	
3	RHN03D-20A-20D-①	40.9	24.2	
	RHN03D-33A-20D-①	52.5	35.8	
5	RHN05D-20B-20D-①	41.3	24.2	
	RHN05D-33B-20D-①	52.9	35.8	
7 1/2	RHN08D-20C-20D-①	48.0	26.8	
	RHN08D-33C-20D-①	60.4	39.2	
10	RHN10D-20C-20D-①	48.0	26.8	
	RHN10D-33C-20D-①	60.4	39.2	

- ① 1 = 208V - 3ph - 60Hz
- ② 2 = 230V - 3ph - 60Hz
- ③ 4 = 460V - 3ph - 60Hz
- ④ 5 = 575V - 3ph - 60Hz

*5 - Lock washer

Options and Technical Data

DECK/BASE MOUNTED ATTACHMENT POINTS—DIMENSIONS

Capacity (t)	Product Code	e1 (in)	e2 (in)	e12 (in)	Deck/Base Mounted
15	RHN15D-20D-16D-①	54.4	43.5	33.7	
	RHN15D-33D-16D-①	66.7		45.9	
20	RHN20D-20D-16D-①	54.4	43.5	33.7	
	RHN20D-33D-16D-①	66.7		45.9	

- ① 1 = 208V - 3ph - 60Hz
- 2 = 230V - 3ph - 60Hz
- 4 = 460V - 3ph - 60Hz
- 5 = 575V - 3ph - 60Hz

*5 - Lock washer

Options and Technical Data

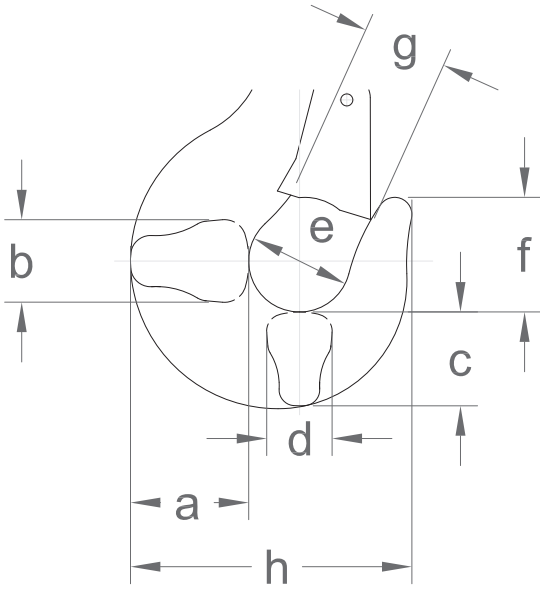

BOTTOM HOOK—DIMENSIONS

Capacity (t)	Product Code*	a (in)	b (in)	c (in)	d (in)	e (in)	f (in)	g (in)	h (in)
2	RHN02D-20A-20D-①	2.2	1.8	1.9	1.5	2.2	2.5	1.6	5.8
	RHN02D-33A-20D-①								
3	RHN03D-20A-20D-①	2.2	1.8	1.9	1.5	2.2	2.5	1.6	5.8
	RHN03D-33A-20D-①								
5	RHN05D-20B-20D-①	2.6	2.1	2.3	1.8	2.5	2.8	1.7	6.7
	RHN05D-33B-20D-①								
7 1/2	RHN08D-20C-20D-①	3.1	2.5	2.6	2.1	2.8	3.1	1.9	7.8
	RHN08D-33C-20D-①								
10	RHN10D-20C-20D-①	3.1	2.5	2.6	2.1	2.8	3.1	1.9	7.8
	RHN10D-33C-20D-①								
15	RHN15D-20D-16D-①	3.9	3.1	3.3	2.6	3.5	4.0	2.4	10.1
	RHN15D-33D-16D-①								
	RHN15U-20D-12D-①	4.9	3.9	4.2	3.3	4.4	5.0	3.2	12.0
	RHN15U-33D-12D-①								
20	RHN20D-20D-16D-①	4.9	3.9	4.2	3.3	4.4	5.0	3.2	12.0
	RHN20D-33D-16D-①								

①
 1 = 208V - 3ph - 60Hz
 2 = 230V - 3ph - 60Hz
 4 = 460V - 3ph - 60Hz
 5 = 575V - 3ph - 60Hz

*Product codes represent Deck/Base Mounted hoists (except RHN15U), but hook dimensions also apply to trolley hoists.

Options and Technical Data

REACTION FORCES AT RATED LOAD—DECK/BASE MOUNTED

Capacity (t)	Product Code	F1 (lbs)	F2 (lbs)	F3 (lbs)	F4 (lbs)	Q1 (lbs)	Q2 (lbs)	Q3 (lbs)	Q4 (lbs)	Moment Mt (ft-lbs)
2	RHN02D-20A-20D-①	1817	1902	654	1292	295	169	393	393	232*
	RHN02D-33A-20D-①	1950	2149	582	1122	328	147	393	393	
3	RHN03D-20A-20D-①	2700	3043	1038	2067	472	270	629	629	372*
	RHN03D-33A-20D-①	2906	3439	916	1795	524	235	629	629	
5	RHN05D-20B-20D-①	4171	4683	1618	3151	736	415	984	984	770*
	RHN05D-33B-20D-①	4480	5272	1435	2744	814	362	984	984	
7 1/2	RHN08D-20C-20D-①	6989	5019	3625	5051	978	741	1475	1475	1514*
	RHN08D-33C-20D-①	7758	6054	3112	4278	1129	627	1475	1475	
10	RHN10D-20C-20D-①	9041	6692	4763	6735	1304	988	1967	1967	2019*
	RHN10D-33C-20D-①	10042	8072	4076	5703	1506	836	1967	1967	
15	RHN15D-20D-16D-①	9297	14086	5835	13988	1894	1684	3147	3147	**
	RHN15D-33D-16D-①	10384	16989	4931	12154	2227	1445	3147	3147	
20	RHN20D-20D-16D-①	12088	16707	7449	17186	2367	2105	3934	3934	**
	RHN20D-33D-16D-①	13494	20243	6316	14899	2784	1807	3934	3934	

- ① 1 = 208V - 3ph - 60Hz
- 2 = 230V - 3ph - 60Hz
- 4 = 460V - 3ph - 60Hz
- 5 = 575V - 3ph - 60Hz

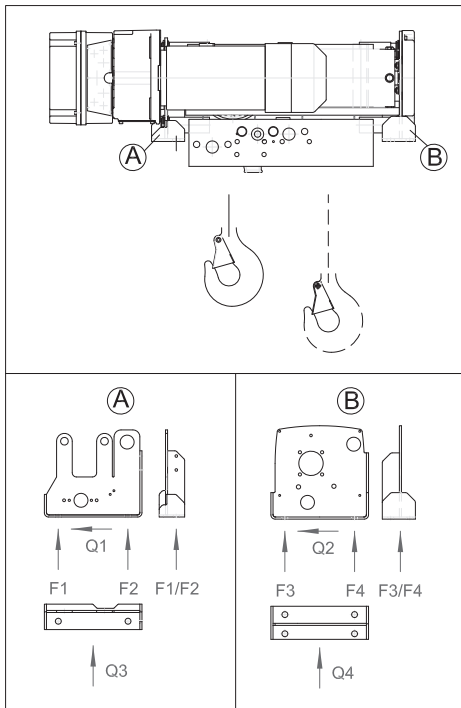

Deck/Base Mounted Hoist (2–10 Ton)

*For 2-10t capacities, the customer's substructure must take up the moment MT from the rope drum. Therefore it must be torsion resistant and level, (max permissible offset, Y = .0787)

**For 15-20t capacities, the design structure compensates for the moment, and the forces are diverted to the fixation points.

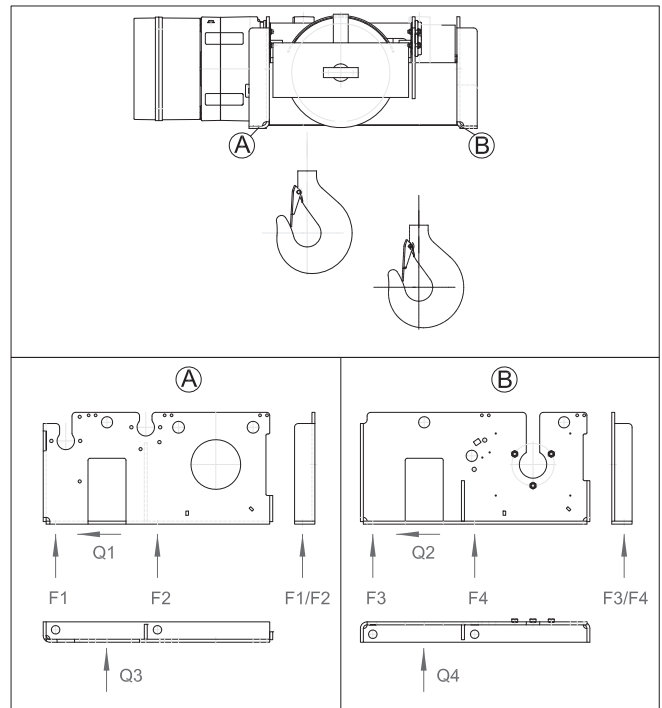

Deck/Base Mounted Hoist (15–20 Ton)

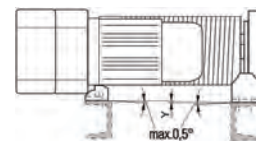

Options and Technical Data

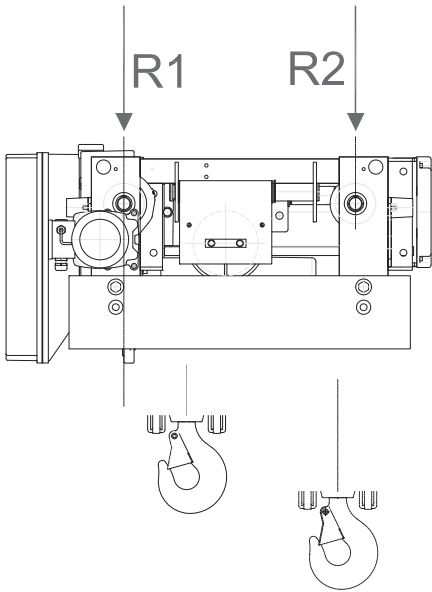

Ultra-Low Headroom
Trolley Hoist

REACTION FORCES AT RATED LOAD—ULTRA-LOW HEADROOM TROLLEY HOISTS

Capacity (t)	Ultra-Low Headroom Trolley Wheel Pair Reaction Forces		
	Product Code	R1 (lbs)	R2 (lbs)
2	RHN02U-20A-20DD-①	2985	2939
	RHN02U-33A-20DD-①	3632	2411
3	RHN03U-20A-20DD-①	4292	4285
	RHN03U-33A-20DD-①	5253	3487
5	RHN05U-20B-20DD-①	6606	7272
	RHN05U-33B-20DD-①	7140	6657
7 1/2	RHN08U-20C-20DD-①	9041	12280
	RHN08U-33C-20DD-①	11940	9813
10	RHN10U-20C-20DD-①	11722	16151
	RHN10U-33C-20DD-①	15569	12850
15	RHN15U-28D-12DD-①	22045	17881
	RHN15U-46D-12DD-①	22226	18478
20	N/A		
	N/A		

①
 1 = 208V - 3ph - 60Hz
 2 = 230V - 3ph - 60Hz
 4 = 460V - 3ph - 60Hz
 5 = 575V - 3ph - 60Hz

Options and Technical Data

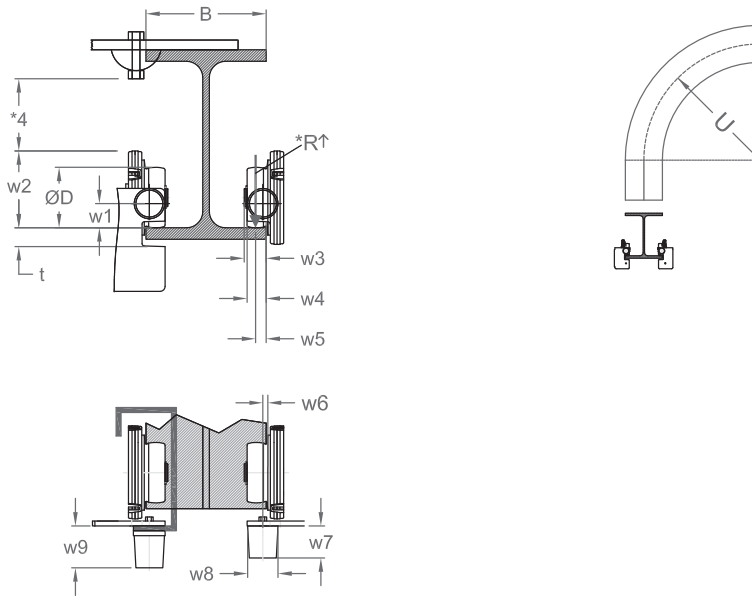

TROLLEY WHEEL—DIMENSIONS

Capacity (t)	Product Code	Wheel Dia. Ø D (in)	w1 (in)	w2 (in)	w3 (in)	w4 (in)	w5 (in)	w6 (in)	w7 (in)	w8 (in)	w9 (in)	U*2 (in)	Maximum Flange Thickness t (in)
2	RHN02U-20A-20DD-①	3.1	1.6	4.1	1.2	1.1	0.5 (0.6)**	0.2	2.1	2.0	2.5	37.4*	0.8
	RHN02U-33A-20DD-①											56.8*	
3	RHN03U-20A-20DD-①	3.1	1.6	4.1	1.2	1.1	0.5 (0.6)**	0.2	2.1	2.0	2.5	37.4*	0.8
	RHN03U-33A-20DD-①											56.8*	
5	RHN05U-20B-20DD-①	3.9	1.6	5.1	1.5	1.2	0.7 (0.9)**	0.2	2.1	2.0	2.5	37.4*	0.9
	RHN05U-33B-20DD-①											56.8*	
7 1/2	RHN08U-20C-20DD-①	5.5	1.5	6.9	N/A	1.8	0.9 (1.3)**	0.5	2.1	2.5	2.5	41.0*	1.3
	RHN08U-33C-20DD-①											61.7*	
10	RHN10U-20C-20DD-①	5.5	1.5	6.9	N/A	1.8	0.9 (1.3)**	0.5	2.1	2.5	2.5	41.0*	1.3
	RHN10U-33C-20DD-①											61.7*	
15	RHN15U-28D-12DD-①	7.9	1.7	10.5	N/A	1.8	0.9 (1.3)**	0.5	2.1	2.5	2.5	N/A	1.7
	RHN15U-46D-12DD-①											N/A	

①
 1 = 208V - 3ph - 60Hz
 2 = 230V - 3ph - 60Hz
 4 = 460V - 3ph - 60Hz
 5 = 575V - 3ph - 60Hz

* - Smaller bend radius upon request.
 ** - () with sloping flange.
 *R - See page 19 for reaction forces R1 and R2.
 *2 - only up to B ≤ 7.9 inches.
 *4 - Observe clearance dimensions.

Options and Technical Data

VARIABLE FREQUENCY DRIVE (VFD)

Consult Customer Service

DUTY CLASSIFICATIONS

Hoist Duty Class	Typical Areas of Application	Operation Time Ratings at K = 0.65*			
		Uniformly Distributed Work Periods		Infrequent Work Periods	
		Max. Time (min/hr)	Max. No. of Starts/hr	Max. Time From Cold Start (min)	Max. No. of starts
H2	Light machine shop fabricating, service and maintenance; loads and utilization randomly distributed; rated loads infrequently handled	7.5 (12.5%)	75	15	100
H3	General machine shop fabricating, assembly, storage, and warehousing; loads and utilization randomly distributed	7.5 (25%)	150	30	200
H4	High volume handling in steel warehouses, machine shops, fabricating plants and mills, and foundries; manual or automatic cycling operations in heat treating and plating; loads at or near rated load frequently handled	30 (50%)	300	30	300

*K = Mean effective load factor.

LIFTING MOTOR RATINGS

Short Time Rating

This rating indicates how long the hoist can be operated continuously at the rated capacity on the cycle below, assuming continued operation for a short time span.

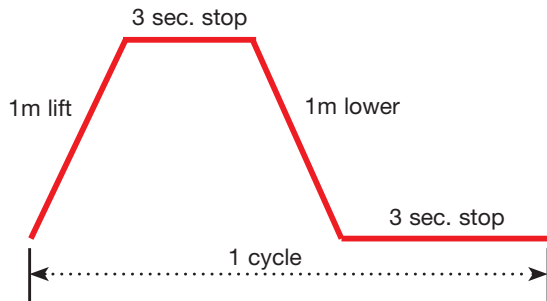

• Dual speed: 30/10 min

Intermittent Rating (Percent ED)

Max. Number of Starts Per Hour

This rating indicates the allowable ratio of motor ON time to motor OFF time, and starts per hour for a hoist operated continuously at 63% of rated capacity on the cycle below, assuming continued operation or repeated starting over a long time span.

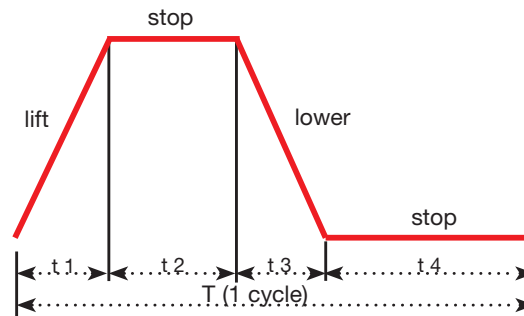

$$\text{Example (single speed): \%ED} = \frac{\text{Motor ON time (t1 + t3)}}{T \text{ (1 cycle)}} \times 100$$

(Where T = 1 cycle (t1 + t2 + t3 + t4) and is not more than 10 minutes.)

Options and Technical Data

COMPLIANCE

Harrington's electric wire rope hoists are produced to comply with:

- ASME B30.16 ("Safety Standard – Overhead Hoists (Underhung)")
- CMAA
- UL508A
- CSA 22.2 NO.14

Product Code For RHN Series Hoists and Trolley Hoists

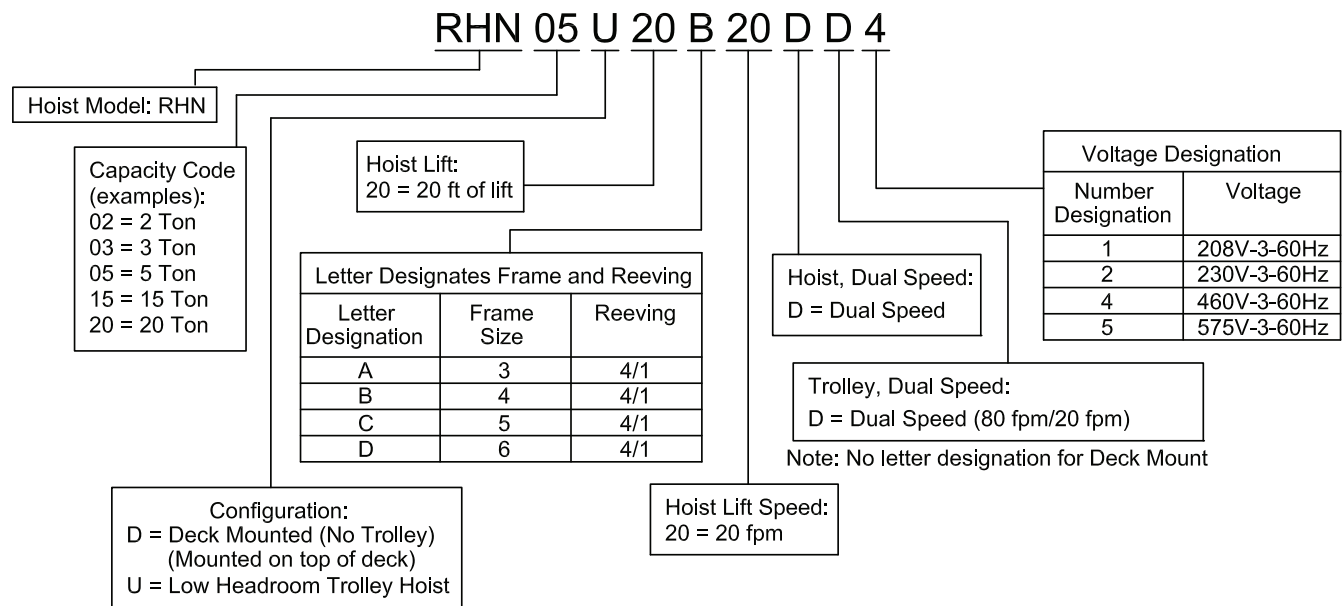

Complete Product Offering

Over the years Harrington has continued to respond to the needs of our customers by further expanding our product offerings. In addition to the many models described in this catalog, our full series of product catalogs, as shown below, will provide you with all of the information you will need to answer questions, specify a product and place an order. For catalog copies or answers to specific product questions, please contact our Customer Service Department by calling 800-233-3010 (Manheim, PA) or 800-317-7111 (Corona, CA) or e-mail customerservice@harringtonhoists.com



Manual Hoist Products Catalog

Refer to this Harrington catalog for detailed information on the following:

- Lever hoists
- Hand chain hoists
- Hoist and trolley combinations
- Low headroom trolley hoists
- Push and geared trolleys
- Hoist load testers

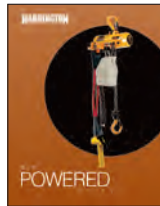

Air Powered Hoists Catalog

Refer to this Harrington catalog for detailed information on the following:

- Compact Mini-Cat with pendant, cord and manipulator controls
- Air hoists with pendant and cord controls
- Air trolleys



Crane Components Catalog

Refer to this Harrington catalog for detailed information on the following:

- End trucks-top running-motorized, geared and push
- End trucks-underhung-motorized, geared and push
- Double girder MAX-E-Lift end trucks
- Convertible push end trucks
- Beam accessory kits



Complete Cranes Catalog

Refer to this Harrington catalog for detailed information on the following:

- Heavy-duty Class C single girder top running and underhung cranes
- Heavy-duty Class C double girder top running and underhung cranes
- Medium-duty top running and underhung push cranes
- Crane control panels



NER/ER Three Phase Electric Chain Hoists Catalog

Refer to this Harrington catalog for detailed information on the following:

- Three phase electric chain hoists and trolleys
- Single phase electric chain hoists and trolleys
- Ergonomic electric chain hoists

CONTACT YOUR NEARBY
KITO DISTRIBUTOR



SOLICITE SUS REPUESTOS A :

ventas@zentrateg.com
www.zentrateg.com

Zentratec SA de CV
A Vial II Junipero Sera 2450 of 117
Juriquilla
Santa Rosa Jáuregui
CP 76230
Querétaro
México

Warranty

All products sold by Harrington Hoists, Inc. are warranted to be free from defects in material and workmanship from date of shipment by Harrington for the following periods:

- Manual Hoists, Trolleys, & Beam Clamps—2 years
- NER2/ER2 Hoists Enhanced Features Models—3 Years
- (N)ER030L(D) All Other Electric and Air Hoists, Trolleys, Crane Components—1 year
- Spare / Replacement Parts—1 year
- NER2/ER2 “The Guardian” Smart Brake—10 years

The product must be used in accordance with manufacturer’s recommendations and must not have been subject to abuse, lack of maintenance, misuse, negligence, or unauthorized repairs or alterations.

Should any defect in material or workmanship occur during the above time period in any product, as determined by Harrington Hoists’ inspection of the product, Harrington Hoists, Inc. agrees, at its discretion, either to replace (not including installation) or repair the part or product free of charge and deliver said item F.O.B. Harrington Hoists, Inc. place of business to customer.

Customer must obtain a Return Goods Authorization as directed by Harrington or Harrington’s published repair center prior to shipping product for warranty evaluation. An explanation of the complaint must accompany the product. Product must be returned freight prepaid. Upon repair, the product will be covered for the remainder of the original warranty period. Replacement parts installed after the original warranty period will only be eligible for replacement (not including installation) for a period of one year from the installation date. If it is determined there is no defect, or that the defect resulted from causes not within the scope of Harrington’s warranty, the customer will be responsible for the costs of returning the product.

Harrington Hoists, Inc. disclaims any and all other warranties of any kind expressed or implied as to the product’s merchantability or fitness for a particular application. Harrington will not be liable for death, injury to persons or property, or for incidental, contingent, special or consequential damages, loss or expense arising in connection with the use or inability whatever, regardless of whether damage, loss, or expense results from any act or failure to act by Harrington, whether negligent or willful, or from any other reason.



WEST

1-888-322-KITO (5486)

EAST

309 - 3815 1st Avenue
Burnaby, BC V5C 3V6
Tel: (604) 291-9955
Fax: (604) 294-8855

6 - 1750 Courtney Park Drive
Mississauga, ON L5T 1W1
Tel: (905) 405-0905
Fax: (905) 405-0906

