

Fabrik-Nr. :	
Serial No.	
No. de fabrication	
Auftrags-Nr.	
Order No.	
Commande No.	
STAHl CraneSystems	Elektra-Seilzug electric-wire-rope hoist palan électrique à câble
Typ SH 6063-12 4/1	Traglast 25000 kg S.W.L./force de levage
Länge 3 length/longueur	Gruppe 1Am group/grupe
Hubhöhe 10,0 m lifting height/hauteur de levage	nach FEM to/ selon
Seil Ø 20 mm rope/cable	Hakenflasche H375-4 bottom hook block/haute
Hubmotor: Typ 12/ZH72-MF hoist motor: type/moteur de levage	
Haupthubgeschw.: 3,5 m/min; main hoisting speed/vitesse de levage principal	18,0 kW, 40 %ED, 120 s/h
Feinhubgeschw.: 0,6 m/min; micro hoisting speed/vitesse de levage principal micro	3,0 kW, 20 %ED, 240 s/h
Fahrwerk: Typ DUE-M77 carriage: type/type de chariot	Laufb. 281 runway/voie de roulement
Hubklasse H2 hoisting class/classe de levage	Laufb. Radius 2,5 m bend radius/ rayon roulement
Fahrmotor: Typ SF18217313 drive motor: type/type du moteur de chariot	Beanspruchungsgr. B3 stress group/grupe de sollicitation
1. Fahrgeschw.: 25,00 m/min; travel speed/vitesse de direction	1,5 kW, 40 %ED, s/h
2. Fahrgeschw.: 6,30 m/min; travel speed/vitesse de direction	0,36 kW, 20 %ED, s/h
Betriebsspannung 460 V; supply voltage/ voltage d'alimentation	60 Hz
Steuerspannung 120 V, 60 Hz; control voltage/tension de commande	Schutzart: IP 55 EN 60529 mode of protection/système de protection
Standort: ständig in der Halle location: always indoor lieu: toujours à l'intérieur	
Umgebungstemperatur ambient temperature/ température ambiante	°C (-20 bis +40C)
Konstruktionsänderungen vorbehalten design changes reserved/sous réserve de modifications de construction	
Kunde Zentrtec SA de CV, Mexico Client/client	
Genehmigt: approved approuver	art place date date firm(firm stamp) firme(cachet de firme)

Radlasten mit Eigenlast: ohne Stoß und Beiwerte
pro Radpaar / per pair of wheels / par paire des roues
wheel load with dead load, without shock and coefficients
pois des roues (avec poids propre), sans choc et coefficients

Traglast / S.W.L. / force de levage 25000 kg

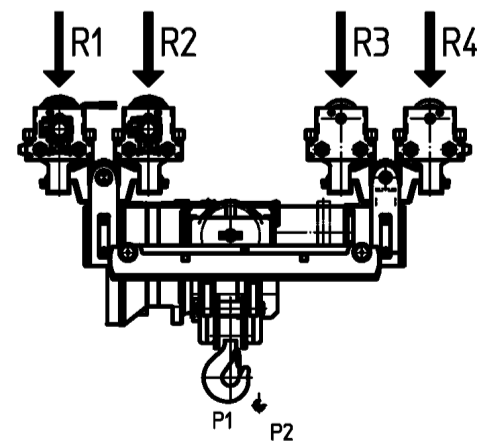

Hakenstellung P1 / hook position P1 / Position du crochet			
R1	77 KN	R2	77 KN
R3	63 KN	R4	63 KN

Hakenstellung P2 / hook position P2 / Position du crochet			
R1	63 KN	R2	63 KN
R3	77 KN	R4	77 KN

Eigengewicht 3000 kg
dead weight / poids propre

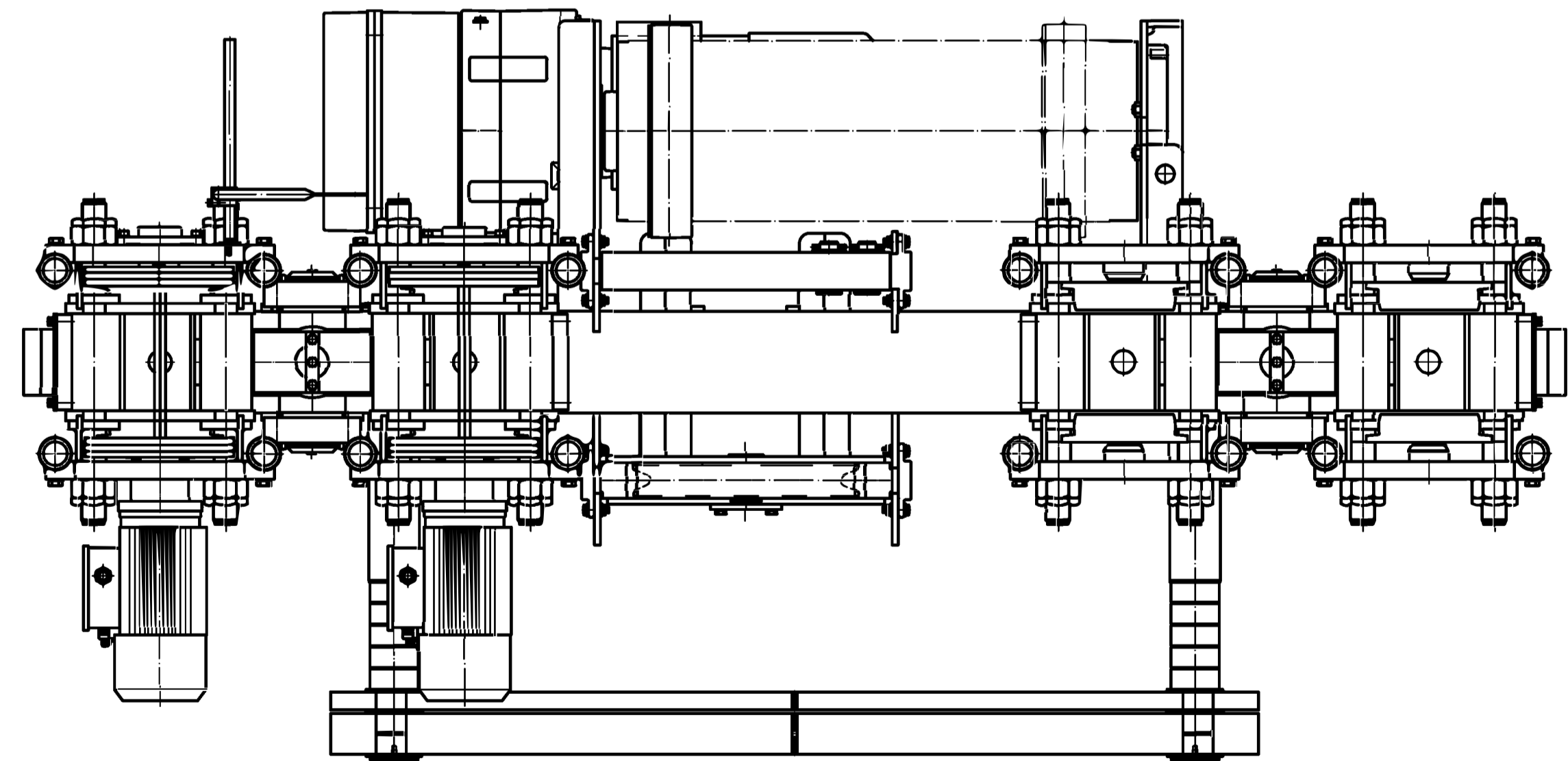

STAHl CraneSystems	Free size tolerance	Duplication No. 25610093909140	Version
	Material	Order No.	NS
		SH 6063-12 4/1 L3	Scale
		DUE-M 77	1:10
	Drawn 24.07.14 Checked Released 24.07.14	Wiesenmaier Wiesenmaier	00 680 262/1
		3810498	Replaced by